

**AS401 / AS401A Hi-End audio operational amplifier****Features**

- Hi-End sound quality
- less then 2 nV/√Hz low input voltage noise
- ultra-low total harmonic distortion+ noise ( $R_L = 600 \text{ Ohm}$   $C_L = 330 \text{ pF}$ ):
  - 0,00015 % at 20 kHz
  - 0,00036 % at 40 kHz
- unity-gain stable at  $R_L=600 \text{ Ohm}$   $C_L=1000 \text{ pF}$
- phase margin at  $G=+1$  &  $R_L = 600 \text{ Ohm}$  without external correction:
  - 125° at  $C_L=100 \text{ pF}$
  - 60° at  $C_L=330 \text{ pF}$
- slew rate  $G=+1$  30 V/μS &  $R_L = 600 \text{ Ohm}$   $C_L = 330 \text{ pF}$
- low input offset voltage 250μV (max)
- bandwidth > 35MHz
- wide supply range +9 V to +36 V ( $\pm 4,5 \text{ V}$  - $\pm 18 \text{ V}$ )
- input current < 1μA
- linear output stage class A
- low small-signal overshoot with capacitive load (100mV output step):
  - 8%  $R_L=600 \text{ Ohm}$ ,  $R_{SL}=0 \text{ Ohm}$ ,  $C_L=100 \text{ pF}$ ;
  - 10%  $R_L=600 \text{ Ohm}$ ,  $R_{SL}=0 \text{ Ohm}$ ,  $C_L=250 \text{ pF}$ ;
  - 30%  $R_L=600 \text{ Ohm}$ ,  $R_{SL}=0 \text{ Ohm}$ ,  $C_L=1000 \text{ pF}$ ;
  - 15%  $R_L=600 \text{ Ohm}$ ,  $R_{SL}=25 \text{ Ohm}$ ,  $C_L=1000 \text{ pF}$
- no phase reversal
- peak-to-peak output voltage swing 32V typ. with  $V_{CC} = \pm 18\text{V}$  and  $R_L=600 \text{ Ohm}$

**DIP-8 hybrid module****Description**

AS401 / AS401A is bipolar-input Hi-End audio operational amplifier and provide ultra-low THD+Noise level - 130dB (1KHz) and -110dB (40kHz) for  $R_L= 600 \text{ Ohm}$  &  $C_L=100 \text{ pF}$ . Amplifier drives a 32 Ohm load at 10 mW and 600 Ohm load at 70 mW. AS401 is unity-gain stable and provides excellent dynamic behavior over a wide range gain and load conditions at a wide supply range of  $\pm 4,5$  to  $\pm 18 \text{ V}$ .

AS401A benefits from additional balance inputs (offset trimming) and additional pin for case shielding.

AS401 / AS401A is a hybrid module with DIP8 footprint.

**Pin information AS401/AS401A**

Pin	AS401	Description	AS401A	Description
1	NC	No internal connection	Bal1	Balance 1
2	-IN	Inverting input	-IN	Inverting input
3	+IN	Non-inverting input	+IN	Non-inverting input
4	V-	Negative power supply	V-	Negative power supply
5	NC	No internal connection	Bal2	Balance 2
6	OUT	Output	OUT	Output
7	V+	Positive power supply	V+	Positive power supply
8	NC	No internal connection	Case	Contact to case / shield

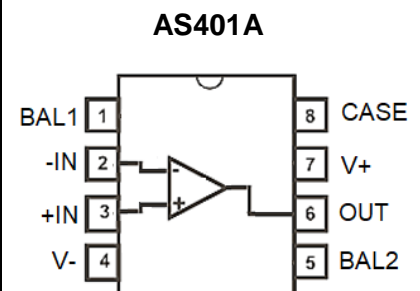
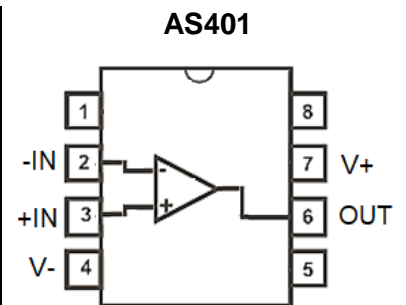

**Absolute Maximum Ratings**

Over operating free-air temperature range (unless otherwise noted) (1)

Parameter	Description	Min	Typ	Max	Unit
Voltage	Supply voltage, $V_s = (V+) - V(-)$			40	V
	Input Voltage	(V-) -1,0		(V+) + 1,0	
	Input differential voltage			±5	
Current	Output short - circuit	Continuous			mA
Temperature	Operating, $T_a$	-40		+50	°C

(1) Stresses beyond those listed under *Absolute – Maximum Ratings* may cause permanent damage to the device. These are stress ratings only, which do not imply functional operation of the device at these or any other conditions beyond those indicated under *Recommended Operating Conditions*. Exposure to absolute-maximum-rated conditions for extended periods may affect device reliability.

**Electrical Characteristic:** at  $T_a = +25^\circ\text{C}$ ,  $V_s = \pm 15\text{ V}$ ,  $R_L = 600\text{ Ohm}$  and  $C_L = 100\text{ pF}$  unless otherwise noted.

Parameter	Test conditions	Min	Typ	Max	Unit
THD+N, Total Harmonic Distortion + Noise	80-kHz measurement bandwidth				%
	$G=+1$ , $f=1\text{kHz}$ , $V_{out}=3\text{V(RMS)}$ , $R_L=600\text{ Ohm}$ , $C_L=330\text{pF}$		0,000015		
	$G=+1$ , $f=20\text{kHz}$ , $V_{out}=3\text{V(RMS)}$ , $R_L=600\text{ Ohm}$ , $C_L=330\text{pF}$			0,00018	
	$G=+1$ , $f=40\text{kHz}$ , $V_{out}=3\text{V(RMS)}$ , $R_L=600\text{ Ohm}$ , $C_L=330\text{pF}$			0,00036	
	$G=+1$ , $f=1\text{kHz}$ , $V_{out}=7\text{V(RMS)}$ , $R_L=600\text{ Ohm}$ , $C_L=330\text{pF}$			0,000024	
	$G=+1$ , $f=20\text{kHz}$ , $V_{out}=7\text{V(RMS)}$ , $R_L=600\text{ Ohm}$ , $C_L=330\text{pF}$			0,00024	
	$G=+1$ , $f=40\text{kHz}$ , $V_{out}=7\text{V(RMS)}$ , $R_L=600\text{ Ohm}$ , $C_L=330\text{pF}$			0,00053	
	$G=+1$ , $f=1\text{kHz}$ , $P_{out}=50\text{mW}$ , $R_L=128\text{ Ohm}$			0,000055	
	$G=+1$ , $f=1\text{kHz}$ , $P_{out}=10\text{mW}$ , $R_L=32\text{ Ohm}$			0,00021	
GBW, Gain-bandwidth product	$G=+1$	35			MHz
SR, Slew rate	$G=+1$		30		V/μS
Full-Power Bandwidth	$G=+1$ , $V_o=1\text{ Vpp}$		4,5		MHz
	$G=+1$ , $V_o=26\text{ Vp-p}$		0,35		
Phase Margin	$G=+1$ $R_L=600\text{ Ohm}$ $C_L=330\text{ pF}$	60			Degrees
Input voltage noise	$G=+1$		2		nV/√Hz
$V_{os}$ Input Offset Voltage	$V_s = \pm 15\text{ V}$			250	μV
	$V_s = \pm 5\text{ V}$			350	
$I_b$ , Input Bias Current	$V_s = \pm 15\text{ V}$			± 1	μA
	$V_s = \pm 5\text{ V}$			± 1,5	
$A_{OL}$ Open-Loop Gain	$V_{out} = \pm 10\text{ V}$ $R_L = 2\text{ kOhm}$		82		V/mV
$V_{out}$ Output Voltage Swing	Output signal - SIN 10kHz $R_L=600\text{ Ohm}$ $V_s = \pm 15\text{ V}$	± 13			V
Short circuit current	$V_s = \pm 15\text{ V}$	25			mA
Small-Signal Overshoot	$R_L=600\text{ Ohm}$ , $R_{SL}=0\text{ Ohm}$ $C_L=100\text{ pF}$			8	%
	$R_L=600\text{ Ohm}$ , $R_{SL}=0\text{ Ohm}$ $C_L=300\text{ pF}$			10	
	$R_L=600\text{ Ohm}$ , $R_{SL}=0\text{ Ohm}$ $C_L=1000\text{ pF}$			30	
	$R_L=600\text{ Ohm}$ , $R_{SL}=25\text{ Ohm}$ $C_L=1000\text{ pF}$			15	
$V_s$ , Supply voltage		±4,5		±18	V
Quiescent current			8	10	mA
Operation temperature range		-40		+50	°C

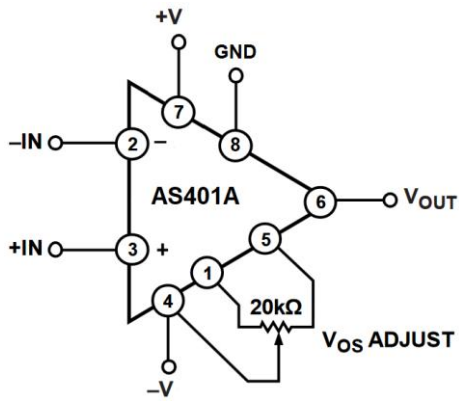

Fig. 1 Offset Null configuration and shielding for AS401A

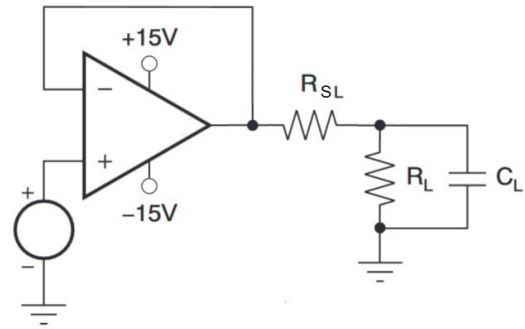
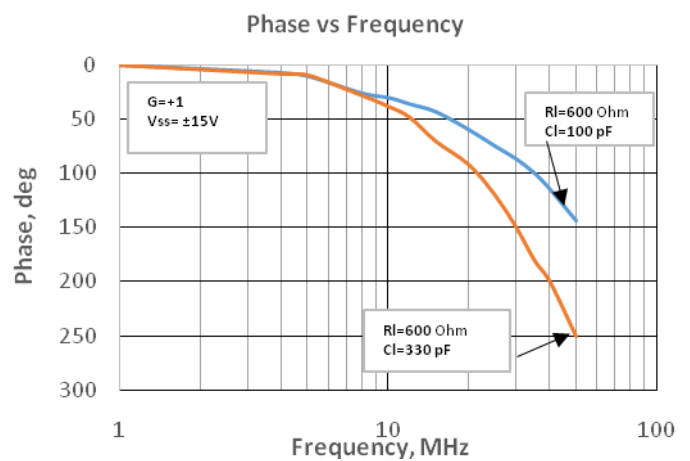
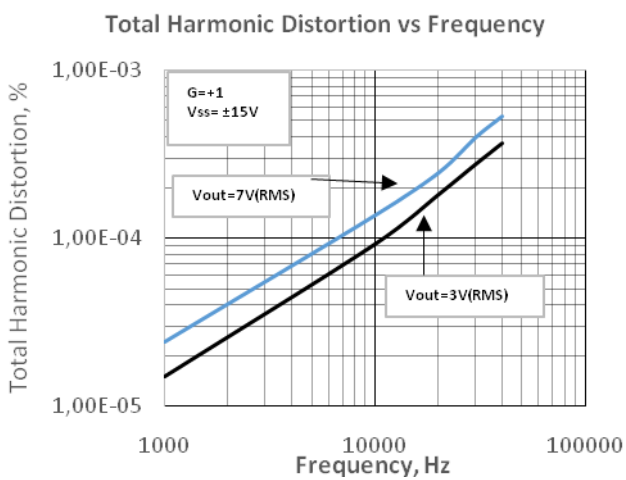
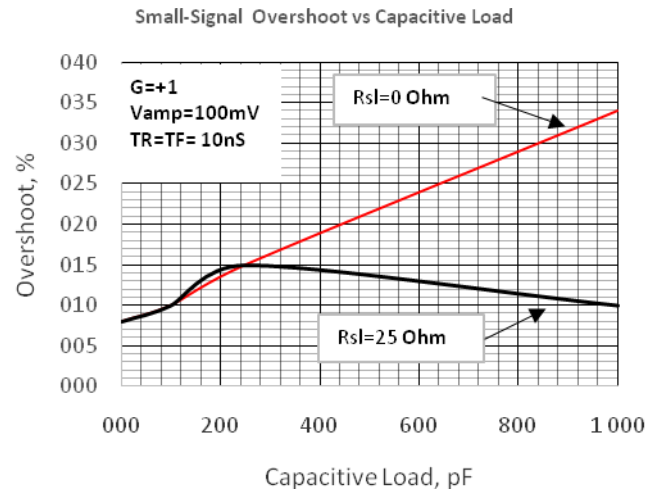
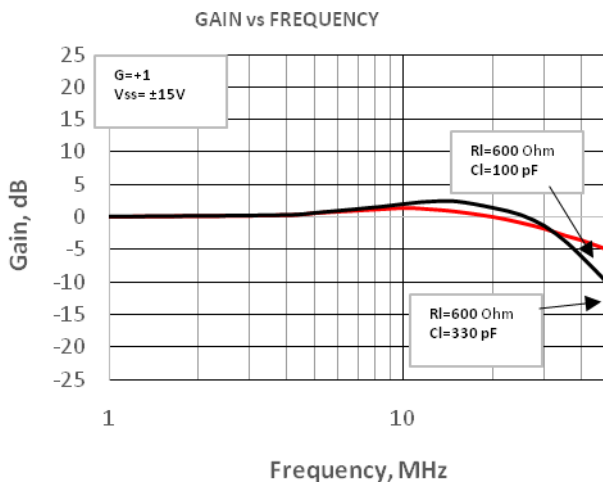

Fig. 2 Measurement schematic (if  $R_{SL}$  not noted, then  $R_{SL}=0$ )

**Typical Characteristics** at  $T_a = +25^\circ\text{C}$ ,  $V_s = \pm 15\text{V}$ ,  $R_l = 600\ \Omega$  and  $C_l = 100\ \text{pF}$  (unless otherwise noted)





Package information

Part number	Package
AS401 , AS401A	DIP8 hybrid module

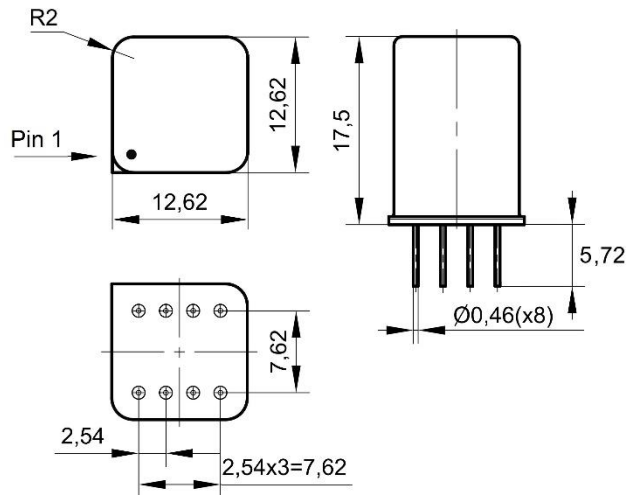

Revision history

Date	Revision	Changes
20-Jun-2019	1	Preliminary version 1
21-Oct-2019	2	Minor changes
18-Apr-2020	3	Package drawing
17-Nov-2020	4	AS401A information added