



## AS3340-HYB Voltage Controlled Oscillator (VCO)

### FEATURES

- DIP-16 footprint
- Pin-to-pin compatible with AS3340
- Minimum influence of PWM on oscillator

### APPLICATIONS

-for electronic synth

**AS3340-HYB**  
**PDIP-16 (300 mil) footprint**

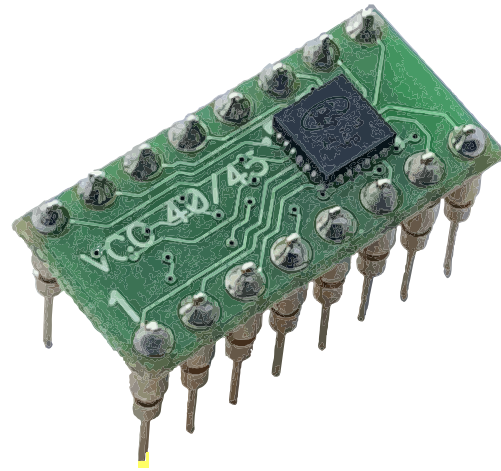

### General Description

AS3340-HYB – voltage controlled oscillator proposed for circuits where requirements on influence of PWM signal on frequency are strict.

AS3340-HYB is based on AS3345F in QFN-24 with addition of PWM comparator based on similar schematics as internal comparator of AS3340. Such solution greatly minimize frequency modulation by PWM control circuit but allows PWM output be compatible with AS3340.

Current consumption from negative and positive source is increased on 1 mA and these issue must be taken into account . All other electrical parameters - according to datasheet AS3340.pdf.

For improved stability of frequency  $V_{ee} = -5 - -6V$  recommended.

### AS3340-HYB Pin Information

PDIP-16, Pin No	Pin Name	Description
1	Scale 1	Scale Adjust 1
2	Scale 2	Scale Adjust 2
3	$V_{EE}$	Negative supply
4	$V_P$	Pulse Output
5	$V_{PWM}$	PWM Control Input
6	$V_{HSI}$	Hard Synchronization Input
7	$V_{HFT}$	High Frequency Track
8	$V_{SO}$	Sawtooth Output
9	$V_{SSI}$	Soft Synchronization Input
10	$V_{TO}$	Triangle Output
11	Cap	Capacitor
12	GND	Ground
13	$V_{LFI}$	Linear FM Input
14	$V_S$	Scale
15	$V_{FCI}$	Frequency Control Input
16	$V_{CC}$	Positive supply

### AS3340-HYB Circuit Block and Connection Diagram

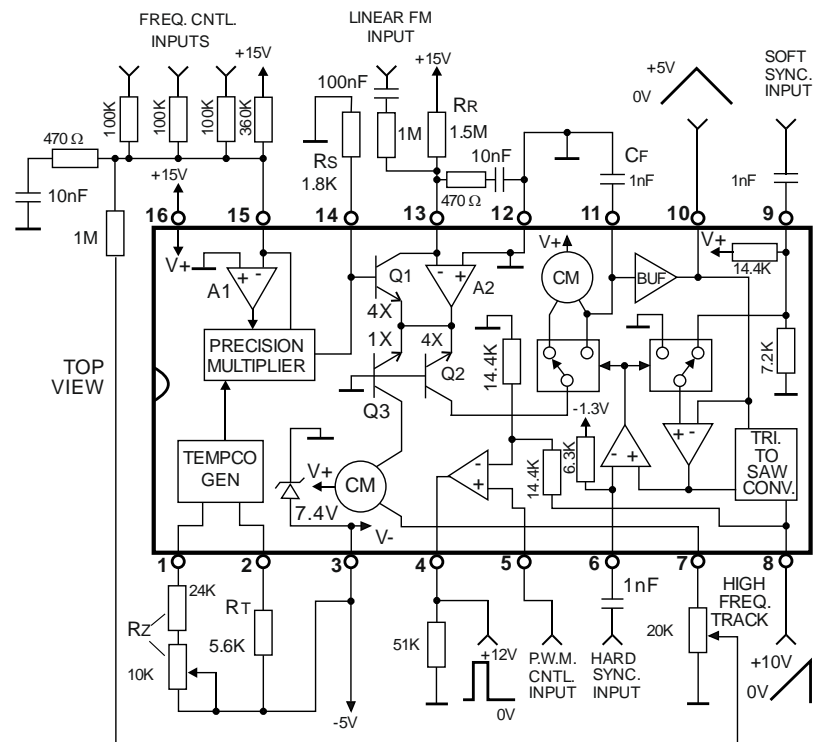



### General Description

AS3340-HYB – voltage controlled oscillator proposed for circuits where requirements on influence of PWM signal on frequency are strict.

AS3340-HYB is based on AS3345F in QFN-24 with addition of PWM comparator based on similar schematics as internal comparator of AS3340. Such solution greatly minimize frequency modulation by PWM control circuit but allows PWM output be compatible with AS3340.

Current consumption from negative and positive source is increased on 1 mA and these issue must be taken into account. All other electrical parameters - according to datasheet AS3340.pdf.

For improved stability of frequency  $V_{ee} = -5 - -6V$  recommended.

#### Absolute Maximum Ratings

Voltage Between $V_{CC}$ and $V_{EE}$ Pins	+24V, -0,5V
Voltage Between $V_{CC}$ and GND Pins	+18V, -0,5V
Voltage Between $V_{EE}$ and GND Pins	-6V, +0,5V
Current through Any Pin	±40mA
Voltage Between Frequency Control Pin or Reference Current Pin and GND Pin	±6V
Voltage Between Multiplier Output Pin and GND Pin	+6V, -1V
Storage Temperature Range	- 55°C to 150°C
Operating Temperature Range	- 25°C to 75°C

### Schematic Diagram AS3340-HYB

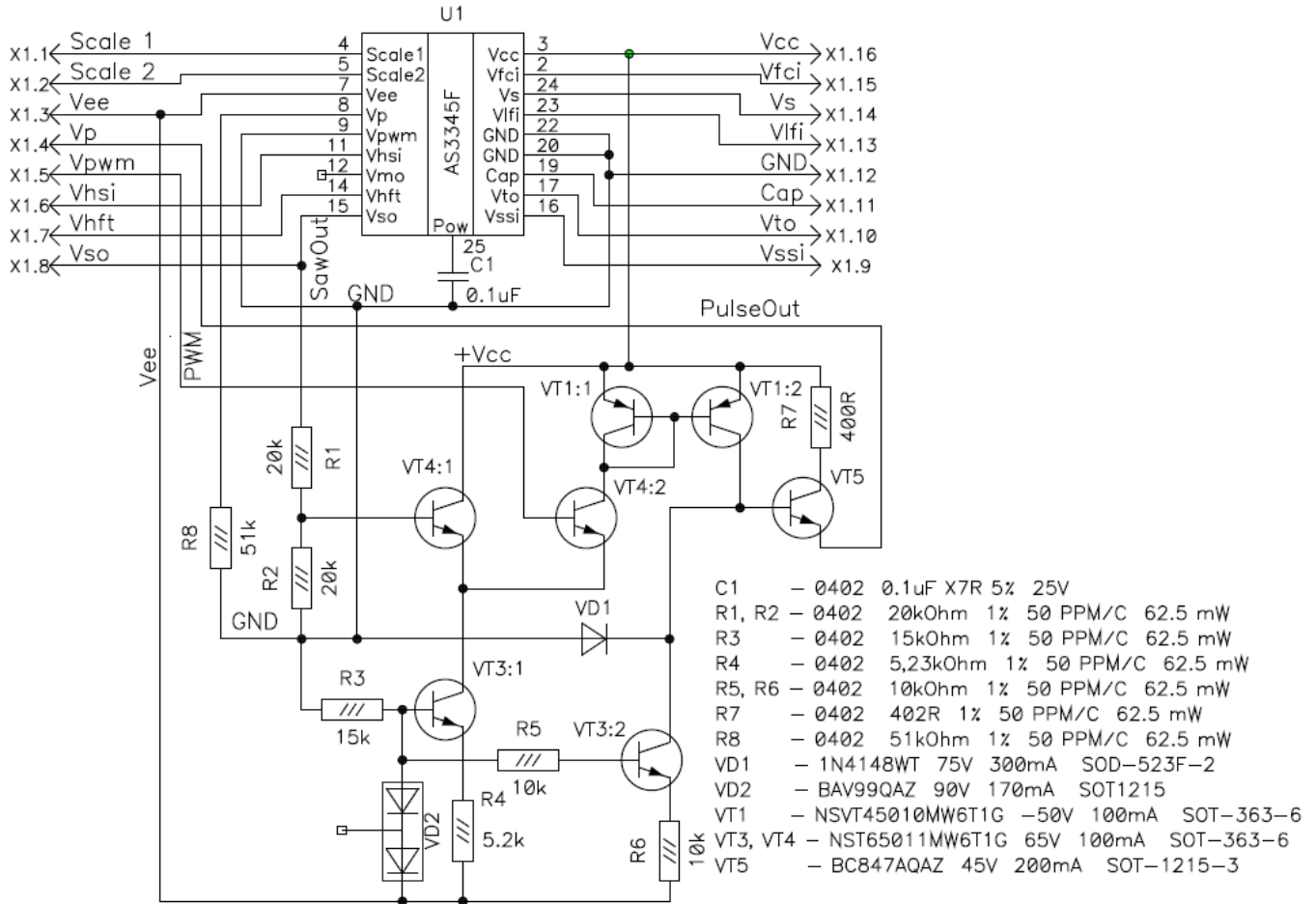



### Stability of Frequency vs PWM

Stability of VCO (in percents) is measured on three samples in dependence from Upwm from 0 till 5V.  
(Ucc=+15 V, Uee=-5 V, Upwm 0 ~ 5 V)

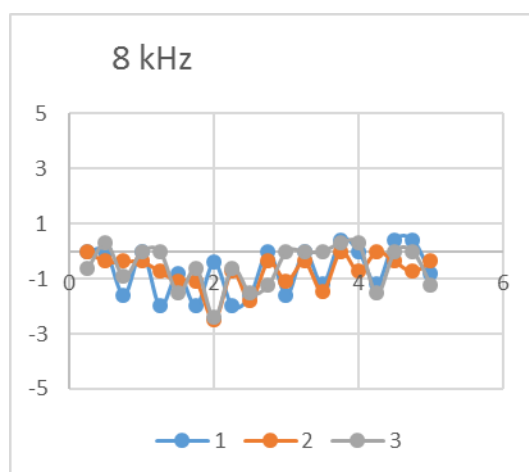
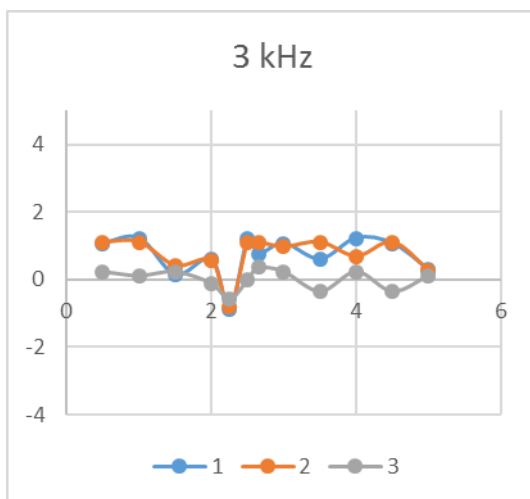
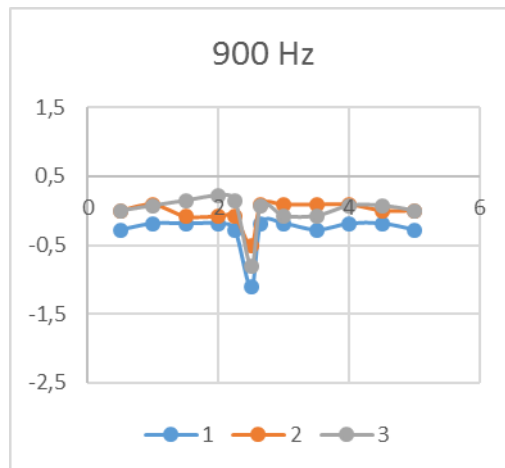
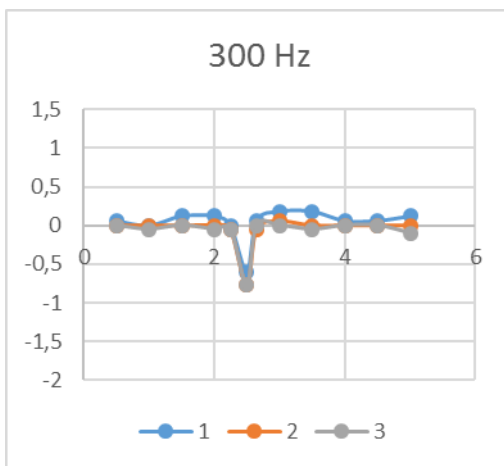
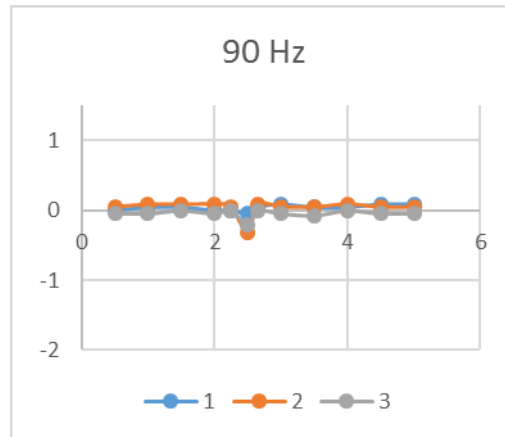
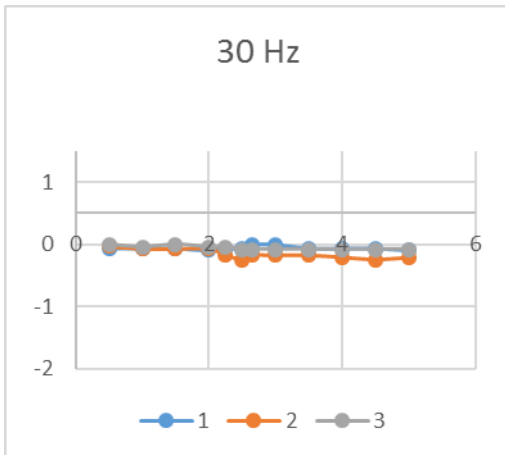



Package Information

Device type	Package
AS3340-HYB	DIP-16 300 Mil footprint

DIMENSIONS (DIP-16 300 Mil footprint)

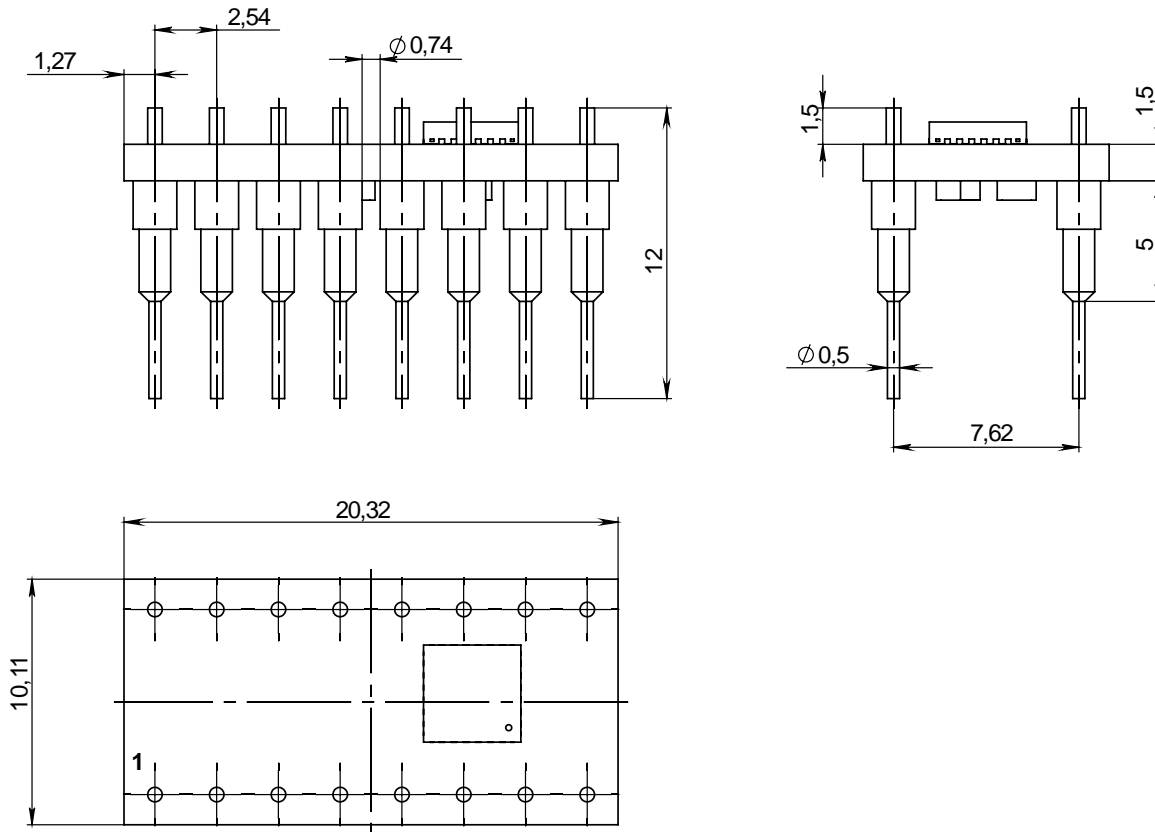

Revision history

Date	Revision	Changes
29-Aug-2018	1	Preliminary version 1
04-Sep-2018	2	Preliminary version 2
12-Feb-2019	3	Stability of frequency vs PWM graphs added