



AS3109 - voltage controlled filter (VCF)

- voltage controllable range – till 15 octave
- accurate exponential frequency scale
- high input impedance buffers
- wide transconductance range
- low input offset voltage
- low control voltage feedthrough - 45 dB typical

AS3109D
SOIC-16 (150 mil)



AS3109
PDIP-16, 300mil, 2.54 mm

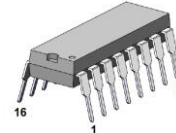

APPLICATIONS

- for electronic music

General Description

AS3109 is a high performance voltage controlled four-pole filter. The four independent sections may be interconnected to provide a wide variety of filter responses, such as low pass, high pass, band pass and all pass. A single input exponentially controls the frequency over greater than a 15 octave range with little control voltage feedthrough. AS3109 benefits from high input impedance buffers.

AS3109 Pin Information

SOIC-16 DIP-16 Pin No	Pin Name	Description
1	GND	Ground
2	In1	Input stage 1
3	C1	Capacitor stage 1
4	Out1	Output stage 1
5	In2	Input stage 2
6	C2	Capacitor stage 2
7	Out2	Output stage 2
8	V _{EE}	Negative power
9	V _C	Control voltage
10	In3	Input stage 3
11	C3	Capacitor stage 3
12	Out3	Output stage3
13	In4	Input stage 4
14	C4	Capacitor stage 4
15	Out4	Output stage4
16	V _{CC}	Positive power

Fig.1 AS3109 Circuit Block and Connection Diagram

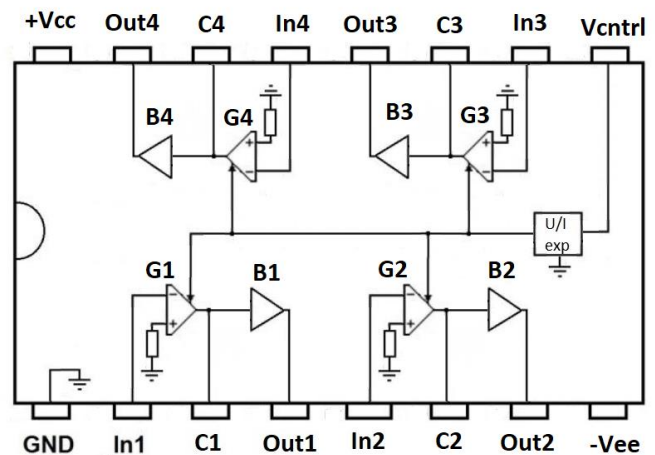



Absolute Maximum Ratings

Voltage Between V _{CC} and V _{EE} Pins	+36V, -0,5V
Voltage Between V _{CC} and GND Pins	+18V, -0,5V
Voltage Between V _{EE} and GND Pins	-18V, +0,5V
Current through Any Pin	±40mA
Voltage Between Inputs and GND Pin	±6V
Voltage Between Control Pin and GND Pin	±6V
Storage Temperature Range	- 55°C to 120°C
Operating Temperature Range	- 25°C to 75°C

Electrical Characteristics

V_{CC}=+15V V_{EE}= -15V T_A= +25°C

Parameter	Min	Typ	Max	Units
Frequency control range	15			octave
Control voltage for 15 octave frequency range	-140		+160	mV
Sensitivity of control voltage	-17,5	-19	-20,5	mV/octave
Tempco of frequency control		0,33		%/°C
Cut-off frequency of filter stage, VC = 0 (C=240 pF, R=68 kΩ, f-3 dB)		250		Hz
Frequency control error		4	10	%
Frequency control , input current		30		nA
Voltage offset of filter stage, VC=0		-12		mV
Voltage offset of serially connected 4 filter stages, VC=0		±0,2		mV
Maximum output voltage , RL=50K		±10		V
Maximum positive output current of buffer (filter stages 1 and 3)	0,6	---		mA
Maximum output positive current of buffer (filter stage 2)	1	---		mA
Maximum output positive current of buffer (filter stage 4)	1,3	---		mA
Buffer voltage slew rate		25		V/μsec
Positive power supply	10	---	+18	V
Negative power supply	-10	---	-18	V
Current consumption, VC = 0		7.5		mA
Maximum current consumption, VC = -200 mV		13		mA

Application information

AS3109 contains four variable transconductance amplifiers whose transconductance is controlled via control voltage (U/I converter – anti-log circuitry). R_{in} in each amplifier is approximately 560Ω . For better performance, external circuit connection to IN must be trimmed.

Fig. 2 Filter stage

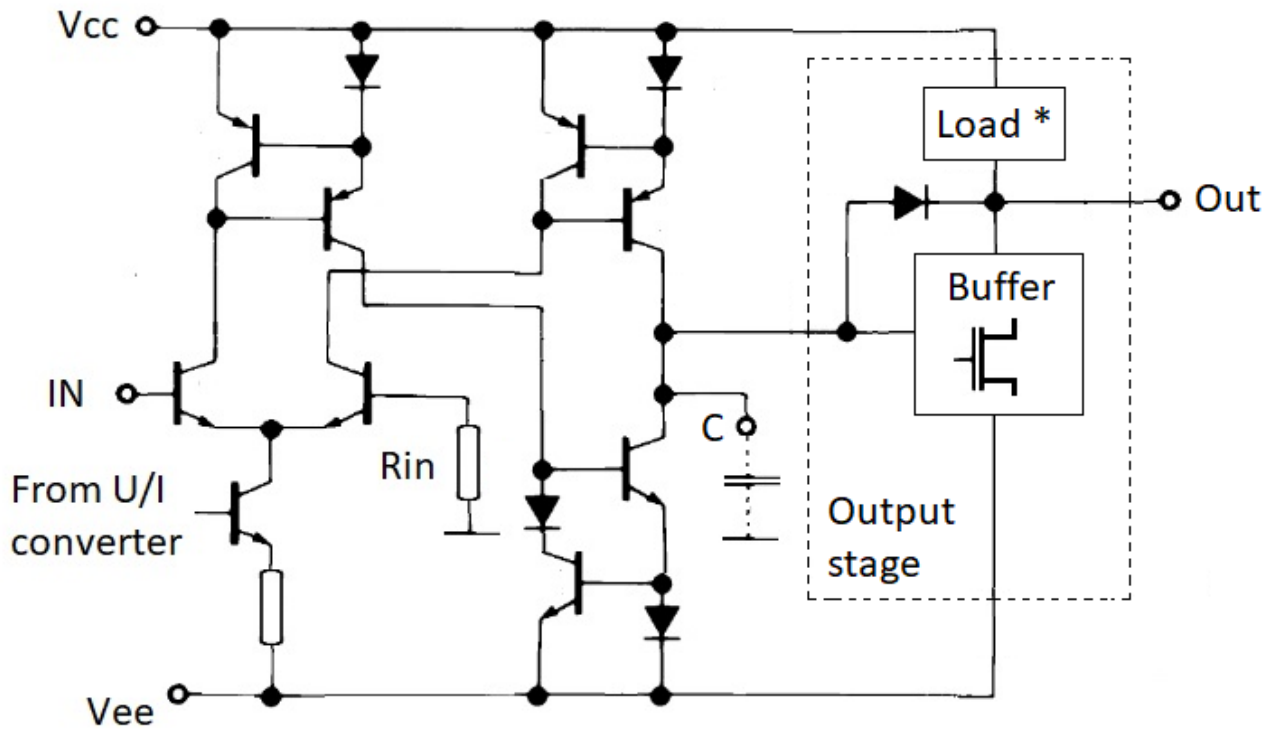

Each filter stage contains high impedance buffer with MOS-type transistor which have different Load* for each stage. Stages 1 and 3 have passive resistor type load, but stages 2 and 4 have active current source load. It means, that behavior of stages with different type of loads is different.

Fig. 3 Typical AS3109 wiring as a voltage controlled low-pass filter

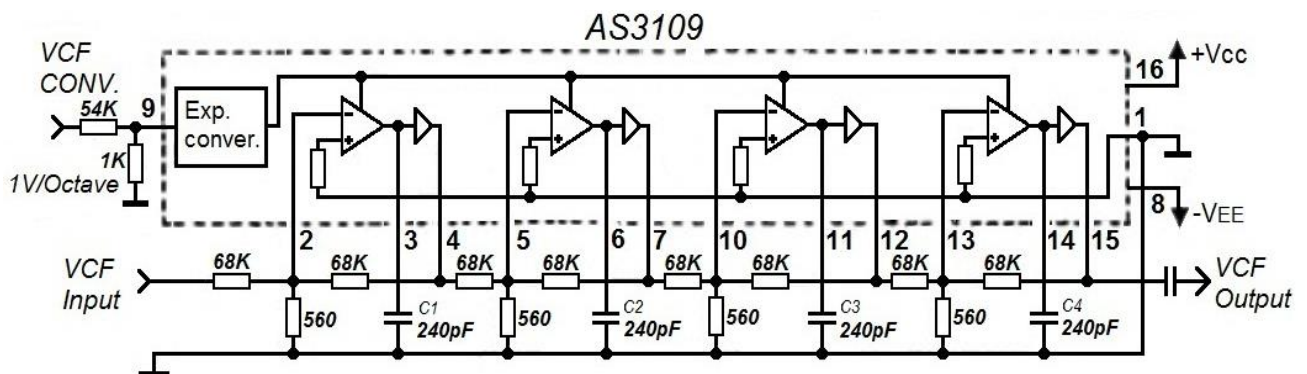



Package Information.

Device type	Package
AS3109D	SOIC-16 (150 Mil)
AS3109	DIP-16 (300 Mil)

SOIC-16 (150 Mil)

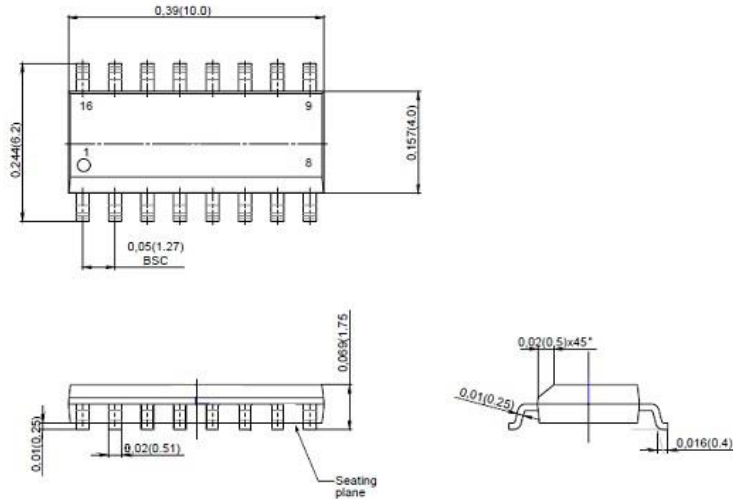

PDIP-16 (300 Mil)

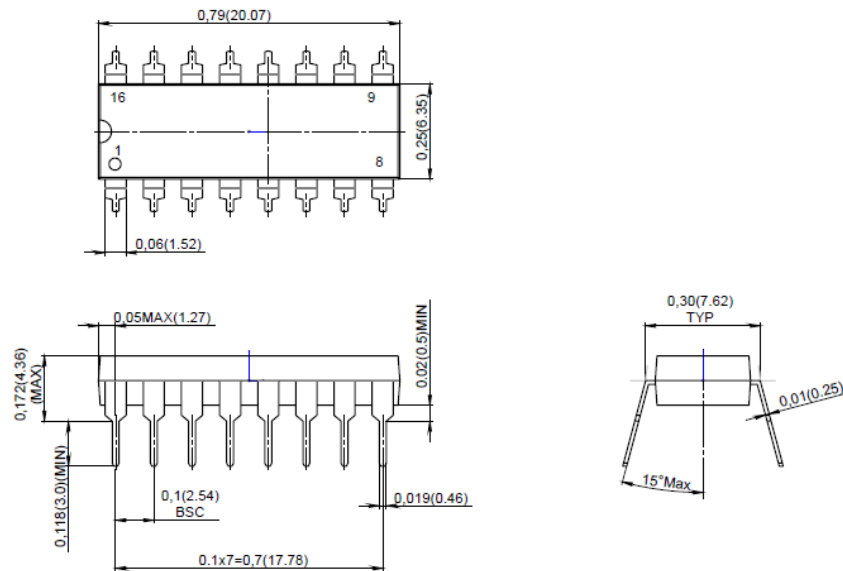

Date	Revision	Changes
10-May-2021	1	Preliminary version 1
20-Dec-2021	1	Version 1
29-Apr-2022	2	DIP version added